

General description

The access doors for rectangular ducting (FAD) and for round ducting (CAD) consist of two panels connected between themselves with two screws, springs and knobs. The inner panel will be slid inside the duct, and the outside panel will then be compressed by tightening both knobs.



Access doors allow easy admittance to the ventilation ducting for the purpose of inspection and cleaning.

Blue knobs are delivered as standard.

Class C : All FAD and CAD-18 up to CAD-40 have been tested and are class C, thanks to their new fitted PUR Sealing Gasket.

CAD-50 and CAD-60 are fitted with the traditional sealing gasket and have not been tested.

Technical specification

PANELS	Material	Galvanized steel Z275
SEALING GASKET	Type	High quality EPDM gasket / PUR*
	Dimension	6 mm x 15 mm
	Density	+/- 33 Kg / m ³
COMPONENTS COMPRESSION SYSTEM	Screws	2 screws: M8x40 or M10x40 crimped on internal panel
	Springs	2 compressions springs
	Knobs	2 plastic knobs with metal insert M8 or M10

Self-adhesive template comes with each door, for accurate cut-out
*It may contain traces of Silicone

Sizes

Door type	Nominal sizes (mm)	Actual Dimensions (mm)			
		A	B	C	D
18	180 x 80	170	72	197	101
20	200 x 100	200	100	219	117
25	250 x 150	250	150	274	186
30	300 x 200	300	200	329	228
42	400 x 200	380	180	412	212
40	400 x 300	380	280	403	303
50	500 x 400	500	400	532	432
60	600 x 450	600	450	627	480

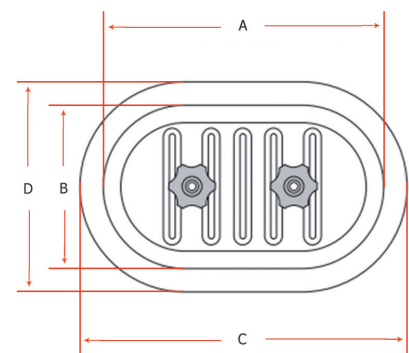

A & B = opening dimensions
C & D = external dimensions

Information contained herein is based on careful tests and experience. It reflects our knowledge and is for guidance purpose only. It is given in good faith and user should ensure that the product is fit for purpose before any application. The quoted values are average and should not be taken as maximum or minimum values for specific purposes. Manufacturer and distributor are not responsible for any non-recommended use or consequential damage.

CAD selection chart for round ducting

Door size Duct dia.	180x80 mm	200x100 mm	250x150 mm	300x200 mm	400x300 mm	500x400 mm	600x450 mm
100 mm	Standard	-	+	-	-	-	-
125 mm	Standard	-	+	-	-	-	-
140 mm	+	Standard	+	-	-	-	-
150 mm	+	+	+	-	-	-	-
160 mm	Standard	+	Standard	-	-	-	-
180 mm	+	Standard	+	-	-	-	-
200 mm	Standard	Standard	Standard	-	-	-	-
224 mm	+	+	+	-	-	-	-
250 mm	+	Standard	Standard	-	-	-	-
280 mm	+	+	+	-	-	-	-
300 mm	+	+	+	-	-	-	-
315 mm	-	Standard	Standard	Standard	-	-	-
355 mm	-	-	Standard	Standard	-	-	-
400 mm	-	-	Standard	Standard	Standard	-	-
450 mm	-	-	Standard	Standard	Standard	-	-
500 mm	-	-	Standard	Standard	Standard	-	-
550 mm	-	-	-	+	+	-	-
560 mm	-	-	-	+	Standard	-	-
600 mm	-	-	-	+	+	-	-
630 mm	-	-	-	+	Standard	Standard	-
700 mm	-	-	-	-	+	+	-
710 mm	-	-	-	-	Standard	Standard	Standard
800 mm	-	-	-	-	Standard	Standard	Standard
850 mm	-	-	-	-	+	+	+
900 mm	-	-	-	-	Standard	Standard	Standard
1000 mm	-	-	-	-	+	Standard	Standard
1120 mm	-	-	-	-	+	Standard	Standard
1250 mm	-	-	-	-	+	Standard	Standard
1400 mm	-	-	-	-	-	-	Standard
1500 mm	-	-	-	-	-	-	Standard
1600 mm	-	-	-	-	-	-	Standard
1800 mm	-	-	-	-	-	-	Standard

For non standard duct diameter it is recommended to use the curved access doors with a diameter directly superior the requested diameter.

+ : Available on request
- : Not available

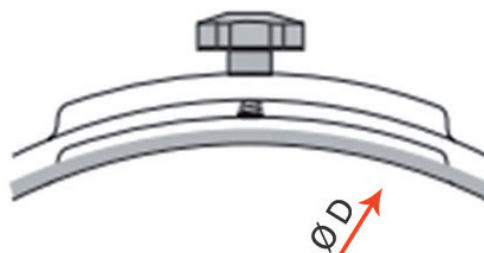

Information contained herein is based on careful tests and experience. It reflects our knowledge and is for guidance purpose only. It is given in good faith and user should ensure that the product is fit for purpose before any application. The quoted values are average and should not be taken as maximum or minimum values for specific purposes. Manufacturer and distributor are not responsible for any non-recommended use or consequential damage.

Recommendations (based on EN 12097)

Access door needs to be fitted :

- before and after every fitting (dampers, fire dampers, filters, duct fans, duct heaters,...)
- after more than one change of direction of more than 45° as from the access door
- after more than one change of airflow as from the access door
- at least every 7,5 m

ROUND DUCTING (CAD)		RECTANGULAR DUCTING (FAD)	
Nominal duct diameter (mm)	Minimal size of access door (mm) A x B	Width of duct where access door is fitted (mm) S	Minimal size of access door (mm) A x B
$100 \leq D < 200$	180 x 80	$S \leq 200$	180 x 80
$200 \leq D \leq 315$	250 x 150	$200 < S \leq 400$	300 x 200
$315 < D \leq 500$	300 x 200	$400 < S \leq 500$	400 x 300
$500 < D$	400 x 300	$500 < S$	500 x 400

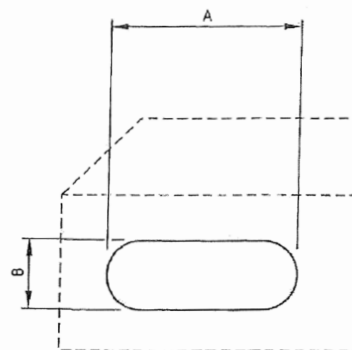
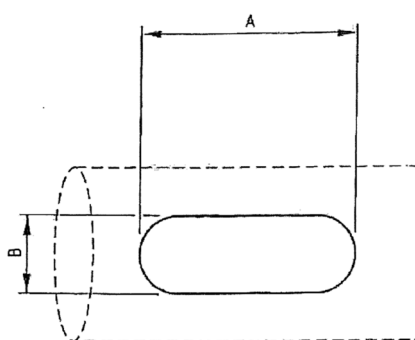

Application

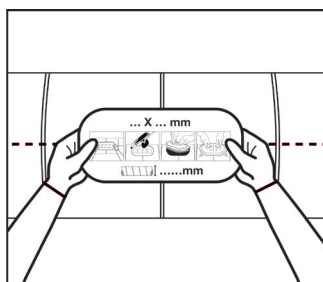

1. Stick self-adhesive template on to duct (a template is provided with each door)

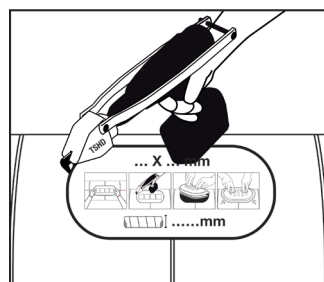

2. Using Turbo Shears or similar cut around template taking care not to exceed the size of the template (the door will function correctly when cut to template size +0 mm -3 mm).

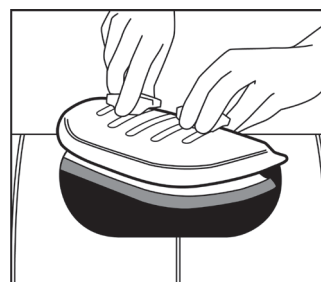

3. Install door by unscrewing the hand knobs until thread is level with top of bolt. Using both hands place the door in the hole at an angle.

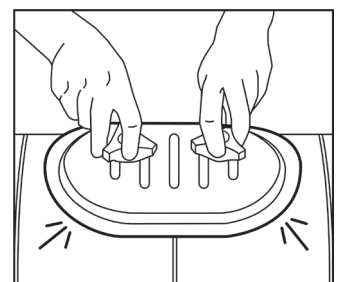

4. Turn straight and pull out slightly to align. Then tighten knobs.

Information contained herein is based on careful tests and experience. It reflects our knowledge and is for guidance purpose only. It is given in good faith and user should ensure that the product is fit for purpose before any application. The quoted values are average and should not be taken as maximum or minimum values for specific purposes. Manufacturer and distributor are not responsible for any non-recommended use or consequential damage.